

# Magneto-resistive Sensors

## Models 1102, 932, and 933XP

### Description

Electro-Sensors' Model 932, 933XP and 1102 Sensors are designed to work with pulse generators that provide magnetic targets, such as our 199SM Wheels, Heavy Duty Pulser Wraps, and Pulser Discs. The Model 932 Magneto-resistive Sensor's exterior is 3/4"-16 threaded aluminum, and it comes with a mounting bracket, jam nuts, and 10' of 3-conductor shielded cable. It can also be ordered with a conduit adapter, allowing it to fit a 3/4" NPT conduit fitting. The 1102 Magneto-resistive Sensor has a non-threaded stainless steel body, and is also supplied with a mounting bracket and 10' of cable. Electro-Sensors' model 1102 is the recommended Magneto-resistive Sensor for use with 199SM Wheels and NEMA C Flange Ring Kits. The Model 933 Explosionproof Magneto-resistive Sensor is mounted in a cast aluminum enclosure which is CSA approved and UL rated for Class I, Groups C and D; Class II, Groups E, F, and G; and Class III environments. It also comes with 10' of 3-wire shielded cable and a mounting bracket.

The sensors can all be powered by 8-24 Vdc and have an NPN open collector output. Magneto-resistive Sensors switch low when the sensing surface is in the presence of a magnetic field and high when the sensing surface is not in the presence of a magnetic field (i.e., the null spaces between the magnets). Figure B on page 2 shows the expected duty cycle of the signal based on the orientation of the sensor when using Electro-Sensors' Pulse Generators. The gap distance between the sensing surface and the pulse generator depends on the strength of the target magnets (See the Sensor Compatibility Table below for gap distances using Electro-Sensors' Pulse Generators). The signal produced by the sensors is compatible with all Electro-Sensors' products, most PLC digital I/O cards, and with other products requiring a digital pulse input signal.

These sensors are also frequently used with single-magnet targets in counting, function start/stop, or orientation alignment of mechanical and electronic indexing equipment applications.

### Pulser Disc

The end of the shaft to be monitored must be center drilled to a depth of 1/2 inch with a No. 21 drill and tapped for 10-32 UNF. After applying Loctite® or a similar adhesive on the threads to keep the pulser disc tight, the pulser disc should be attached decal side out with the supplied 10-32 UNF machine screw and lock washer. Discs can be used with either of the 932, 933XP, and 1102 sensors.

### Pulser Wrap

Pulser Wraps are custom manufactured to fit the shaft they will be mounted on. When the wrap is shipped, four Allen-head cap screws hold the two halves of the wrap together. These screws must be removed so that the wrap is in two halves. Place the halves around the shaft, reinsert the screws and torque them to 8 foot pounds. Pulser wraps can be used with either of the 932, 933XP, and 1102 sensors.

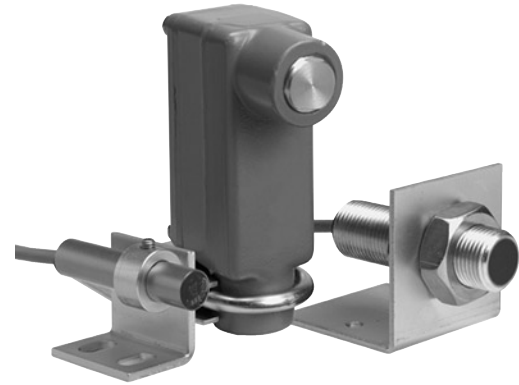

### Sensor Installation

The 932 and 1102 Magneto-resistive Sensors are encased in clear epoxy, allowing the user to see the sensing device position inside the housing (see Figure A). Figure B shows how the angle of the sensing device alters the generated pulse's duty cycle. The longer the sensor is in the null, the longer the sensor will be switched high. When using the Magneto-resistive Sensor in applications in which the duty cycle of the pulse output is critical, watch the sensor output with an oscilloscope and position the sensor with the sensing device perpendicular to the direction of rotation. Turn the monitored shaft and observe the output changes on the oscilloscope while slowly adjusting the sensor until the desired output is achieved. A 45° angle will produce approximately a 50/50 duty cycle and is recommended for most applications.

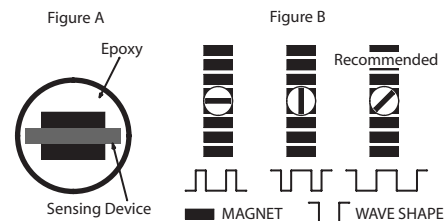

**Note:** (for 933XP only) Do not attempt to turn the sensing head as this may violate the explosionproof rating standards for the unit.

### Electrical Connections

Magneto-resistive Sensors are designed for use with devices that have an internal pull-up resistor. If the device that will receive the signal does not have a pull-up resistor, a 2.2 K ohm resistor must be placed between the sensor supply voltage and the sensor signal output (see Wiring Diagram).

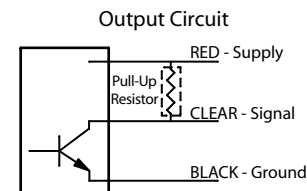

**Important Note:** Exercise caution when wiring the sensor, as damage will occur if the SIGNAL and SUPPLY lead wires are accidentally shorted. Carefully double-check all connections before applying power to the unit.

6111 Blue Circle Drive  
Minnetonka, MN 55343  
Phone: 952.930.0100  
Fax: 952.930.0130  
ISO 9001:2000 Certified



Free Catalog and Application Assistance  
1.800.328.6170  
Visit Us Online  
www.electro-sensors.com  
990-001500 Revision A

## Wiring Chart

Color	Connect To	Description
Shield	Circuit Ground	Transducer Ground
White or Clear	Signal	Transducer Signal
Red	Supply	Transducer Supply
Black	Circuit Ground	Transducer Ground

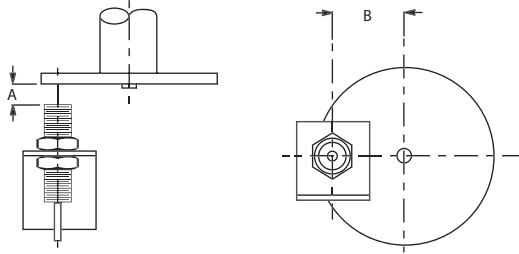

Figure 1: 932 and Pulser Disc

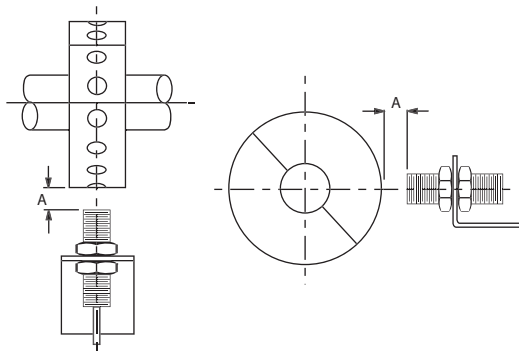

Figure 2: 932 and Pulser Wrap

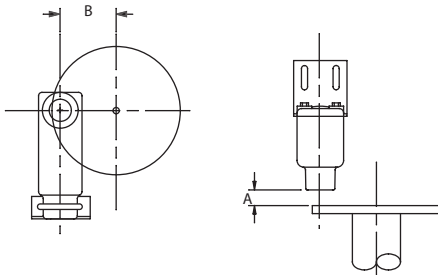

Figure 3: 933XP and Pulser Disc

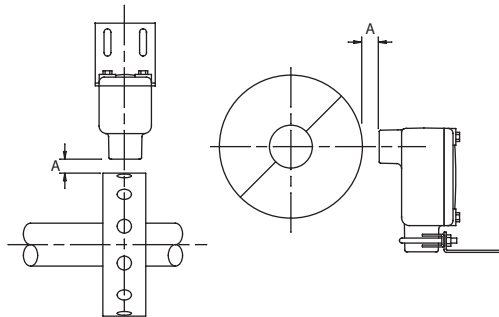

Figure 4: 907 and Pulser Wrap

## Sensor Specifications

Supply	8-24 Vdc @ 10 mA
Output Type	NPN Open Collector
Current sink	20 mA Max
Operating Frequency	0 Hz to 20 kHz
Temp Range	-20° C to +60° C
Gap Distance	1/4 inch +/- 1/8 inch
Cable Length	10 feet standard (1500 feet max.)
Body Material	<b>932:</b> Aluminum <b>933XP:</b> Cast Aluminum <b>1102:</b> Stainless Steel
Ratings (933XP)	Cast Aluminum, C.S.A. Approved. Meets UL Class I Group C, D; Class II Groups E, F, G; Class III
Cable	3-Conductor, Shielded
Mounting Bracket	Plated Steel, Included

## Part Dimensions

### Model 932 Sensor

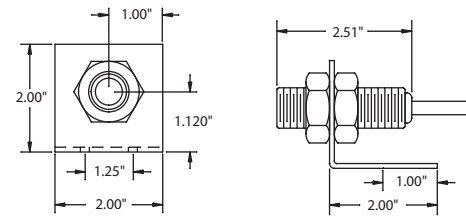

### Model 933XP Sensor and Mounting Bracket

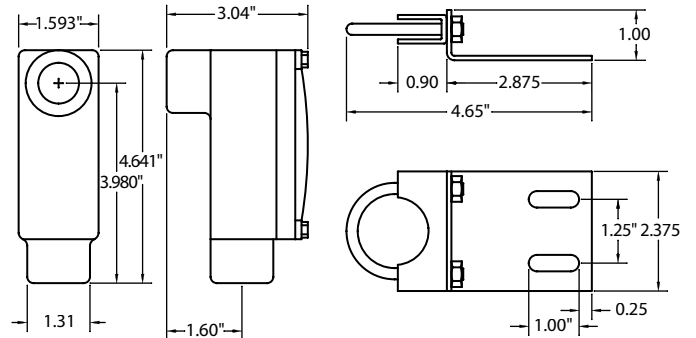

### Model 1102 Sensor

