



Ideal for control cabinet mounting



LRB 1000/2000 Speed Switch DIN Rail Mount or Stand Alone

- Dial-in calibration via rotary switches does not require power
- 1-100 and 10-1000 rpm set point ranges (others available)
- Built-in start delay and signal loss protection
- UL and CSA approved to applicable standards
- Single or double set point relay protection
- Fail-safe operation in overspeed or underspeed mode
- 5-Year Limited warranty on all products*

* Excludes motor controllers and MKS products

Product Information

Description

The LRB-Series Speed Switches are complete rotation monitoring systems with one or two adjustable set points designed to detect unwanted overspeed, underspeed or stoppage of pumps, drive trains, screw conveyors, tail pulleys, fans/blowers, crushers and more. In the event of rotational failure, the LRB's relay can be used for equipment shutdown or to provide an alarm. The standard LRB system includes either the LRB-1000 (1 set point) or LRB-2000 (2 set points) Speed Switch, a 906 Sensing Head and a 255 Pulser Disc. Electro Sensors Speed Switches bring efficiency and safety to your operations by preventing machine damage, product waste and costly downtime.

Principle of Operation

The LRB is supplied with a shaft-end mounted Pulser Disc (or optional split collar Pulser Wrap) which generates an alternating magnetic field that is picked up by our large-gap, non-contact sensor. The sensor transmits this speed signal as a digital pulse (frequency) to the switch via a 3-conductor shielded cable. The LRB decodes this frequency signal to determine shaft speed, and compares this to the pre-adjusted set point. The relay output can then be used for equipment shutdown or to provide an alarm, assuring machine protection and process integrity. The LRB is fail-safe; any malfunction during operation will de-energize the control circuit.

Dimensional Drawings • LRB Series Speed Switches

LRB Series Module

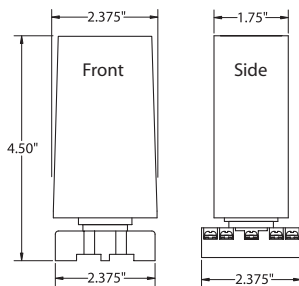

Terminal Block

Stock No. 569-006100

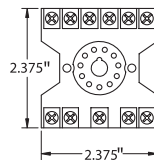

907 Explosionproof Sensor

Stock No. 775-000600

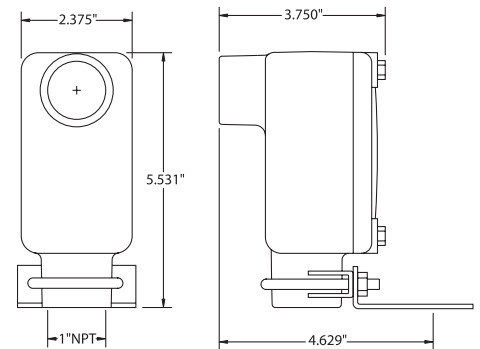

906 Digital Sensor

Stock No. 775-000500

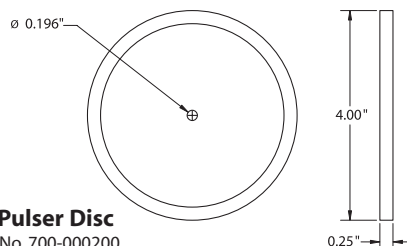
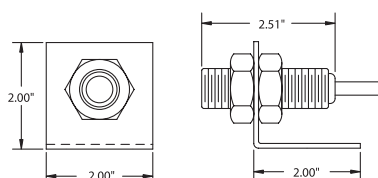

255 Pulser Disc
Stock No. 700-000200

Large-Gap Sensor Installation

The standard sensor is supplied with a mounting bracket and two jam nuts, and is easily adjustable to achieve the proper gap distance. The optional explosionproof sensor is supplied with a slotted mounting bracket, also easily adjustable.

Sensors should be installed allowing the center of the magnets to pass in front of the center of the sensing head during rotation. The gap distance between the sensor and disc or wrap (dimension A in figures 1 & 2) is $3/8" \pm 1/8"$. When using a standard 4" Pulser Disc, the center of the magnetized area of the disc (dimension B in Figure 1) is 1-3/4" from the center hole of the disc.

Standard 906 Sensor and Disc*

Figure 1

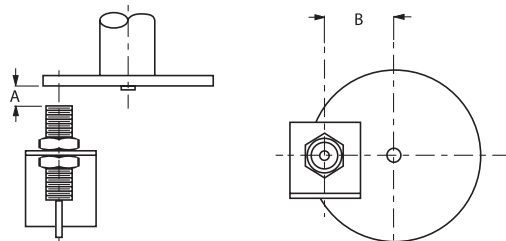

Standard 906 Sensor and Wrap*

Figure 2

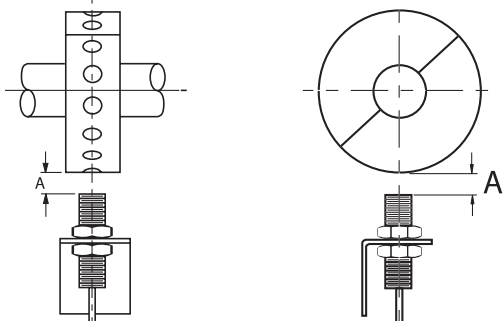

* 907 Explosionproof Sensing Head is also compatible with discs and wraps.

Available Options

- Explosionproof 907 sensing head.
- Split Collar Pulser Wrap for when end of shaft is inaccessible. Wraps available in the following materials:
 - PVC
 - Aluminum
 - Stainless Steel
- Stainless Steel Disc-Guards
- EZ100 Easy Mount Bracket Assembly for use with 907 Series explosionproof sensor (figure 3 below).

(Consult factory for further options.)

Optional EZ100 Easy Mount Bracket

Figure 3

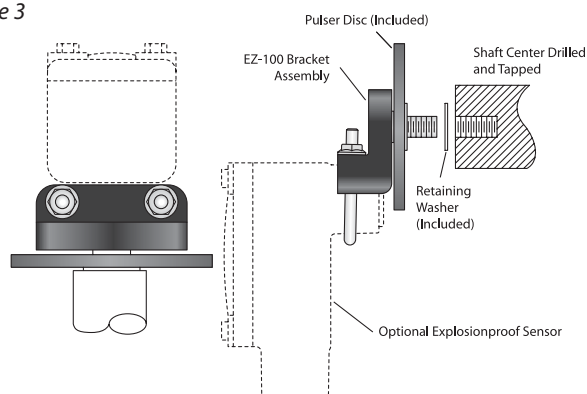

LRB Special Options

Special options are also available to modify the standard functions of LRB Series Switches, these include:

- Increased or decreased start delay interval
- No start delay
- Set point range
- Increased or decreased set point hysteresis
- Signal loss protection in overspeed mode

LRB-1000/2000 Specifications

Input Power

Voltage... 115Vac, 60 Hz std, 230 Vac, 12 Vdc, 24 Vdc optional

Sensor Input Signal

Type..... NPN Open Collector
 Amplitude..... 5Vdc
 Pull-Up..... 4.7 K Ohms
 Sensor Supply..... 15 Vdc @ 50 mA max
 Frequency Range..... 0-666.67 Hz

Set Point Data

Number Available One or Two
 Actuation State Under or Over Speed
 Set Point Relays
 ... LRB-1000: One form C, SPDT isolated 5A 115 Vac resistive
 ... LRB-2000: Two form C, SPDT isolated 5A 115 Vac resistive

Set Point Adjustment

..... Rotary Switches: (1) tens and (1) ones digit
 Start Delay 10 Seconds (Fixed)
 Hysteresis..... 6%

General Specifications

Housing and Cover..... NEMA 1
 Electrical..... Approved to UL 508 and
 CSA C22.2 #14-95 Standards
 Mounting..... DIN Rail Mount or Stand-Alone
 906 Sensor Aluminum 3/4" - 16 UNF body with
 10 ft of 3-conductor shielded cable.
 907 Explosionproof Sensor... Cast Aluminum, CSA Approved.
 Meets UL Class I, Group D; Class II, Groups E, F, G; Class III
 255 Pulser Disc ... Nylon® 12, 4" diameter, 16 magnetic poles
 Gap distance..... $3/8" \pm 1/8"$
 Operating Temperature -40° C to + 60° C*

* Contact factory for higher temperature ranges.
 Specifications subject to change without notice.

ES-398 Rev D