

# 199SM/198EM Magnet Wheels

## Pulse Generator Products for Rotating Shafts

### Features

- Custom mounting hubs
- Produces 60 or 120 pulses per revolution
- End-of-shaft or over-shaft mount
- NEMA C Flange Ring Kit compatible
- Non-contact sensing
- 10,000 rpm maximum speed
- Available without aluminum hub

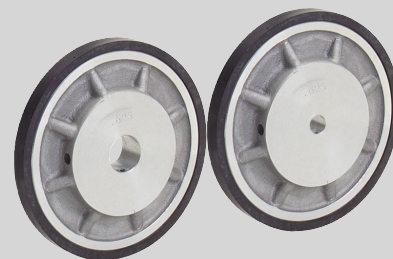

### Description

The 199SM and 198EM Magnet Wheels comprise a ferro-magnetic nylon ring with 120 alternating magnetic poles and an aluminum hub. The wheel is 3.75" in diameter with the magnetic surface on the outside circumference of the wheel. The magnets are rectangular and evenly spaced between non-magnetized spaces. The wheel is typically mounted on a shaft up to 3" in diameter. Our shaft mount wheels are custom-bored to slide snugly onto the shaft, and are then secured with two set screws. Many standard hub sizes are in stock, including common NEMA C Frame Motor sizes.

### Sensor Compatibility

The 199SM and 198EM Magnet Wheels are compatible with Electro-Sensors' Hall Effect and magnetoresistive sensors.

Hall Effect Sensors: The signal switches high on one pole and low on the opposite pole, producing 60 pulses per revolution with a 50/50 duty cycle.  
*Recommended Hall Effect Sensor: Electro-Sensors model #1101.*

Magnetoresistive Sensors: The signal switches low in the presence of a magnetic field of either polarity, and high in the spaces between the magnetic poles, producing 120 pulses per revolution. The 50/50 duty cycle of the magnetoresistive sensor will vary slightly depending on the orientation of the sensing surface to the ring (see Magnetoresistive Sensor literature, #ES-114). *Recommended Magnetoresistive Sensor: Electro-Sensors Model #1102.*

The signal generated by the Magnet Wheels and any of Electro-Sensors' sensing heads is compatible with all Electro-Sensors' products as well as most PLCs, motor speed controls, tachometers, and other pulse input devices. See the Sensor Comparison/Compatibility Chart for more information on Sensors.

### Sensor Installation

Mount the sensor so that the sensing surface is centered and perpendicular to the magnetic surface on the outside edge of the magnet wheel. Use the chart below to determine appropriate gap distances.

### Sensor Comparison/Compatibility Chart

	Hall Effect		Magnetoresistive	
	906	1101	932	1102
Pulses Generated per Revolution	60	60	120	120
Wave Type	Square	Square	Square	Square
Output Type	NPN	NPN	NPN	NPN
Duty Cycle of Pulses	50/50	50/50	≤50/50	≤50/50
Ring Kit Compatible	No	Yes	No	Yes
Gap Distance	0.025"	0.040"	0.025"	0.040"

### Mounting

**End Mount:** Center-drill the shaft to a depth of 0.5" with a No. 21 drill, then tap for a 10-32 UNF screw. Apply Loctite® or a similar adhesive to the screw threads and secure onto the end of the shaft with the provided 10-32 mounting screw. Torque the mounting screw to a maximum of 8-10 foot pounds.

**Shaft Mount:** Slide the custom hub over the shaft to the desired position and tighten the two set screws (provided).

### Specifications

Material	Ferro-magnetic nylon
Number of Magnet Poles	60 North, 60 South, alternating
Gauss Rating of Magnets	400 +/- 50
Operating Temperature	-40°C to 150°C
Maximum Operating Speed	10,000 rpm at ambient temp.
Hub Material	Aluminum or stainless steel
Maximum Hub Bore	3.0 inches

*Specifications subject to change without notice.*

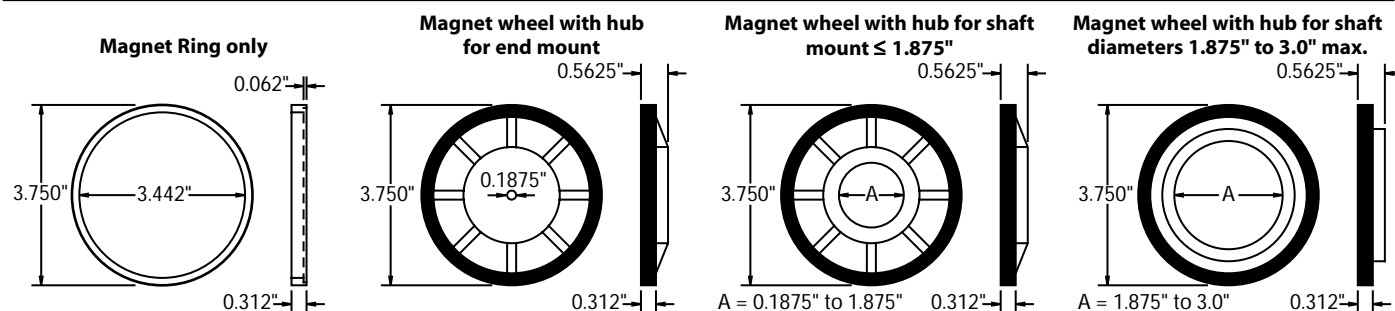

Free Catalog and Application Assistance:

**1-800-328-6170**

ISO9001:2000

6111 Blue Circle Drive, Minnetonka, MN 55343 USA



Visit us online:  
**www.electro-sensors.com**

Phone: 952-930-0100 Fax: 952-930-0130