

Features

- Mounts directly to the tapped shaft
- Can be used with optional Mounting Magnet if shaft is not tapped
- Pulser disc is included
- EZ-3/4in is for the 906 and 932 sensors
- EZ-18mm is for Series 18, ST420 Series, and SpeedTalker-DN(BH) Sensors

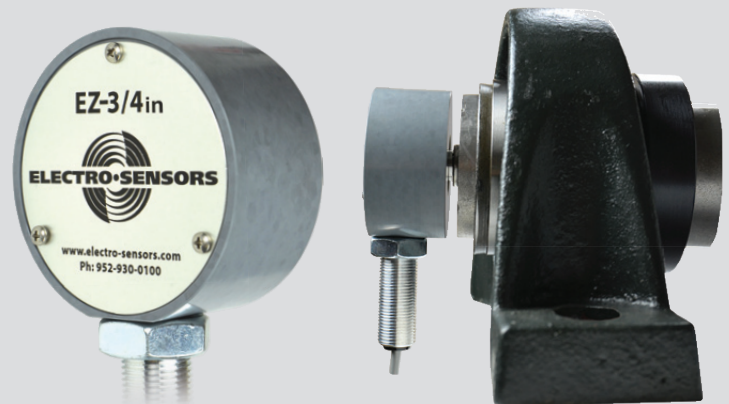

Description

The EZ-18mm and the EZ-3/4in Easy Mount Bracket Assemblies are used with Electro-Sensors speed sensors to generate pulses or 4-20 mA signals for use with display meters, speed switches, or PLC inputs. The EZ-18mm and EZ-3/4in mount directly to the shaft so no other mounting brackets are needed. A securing strap is also provided.

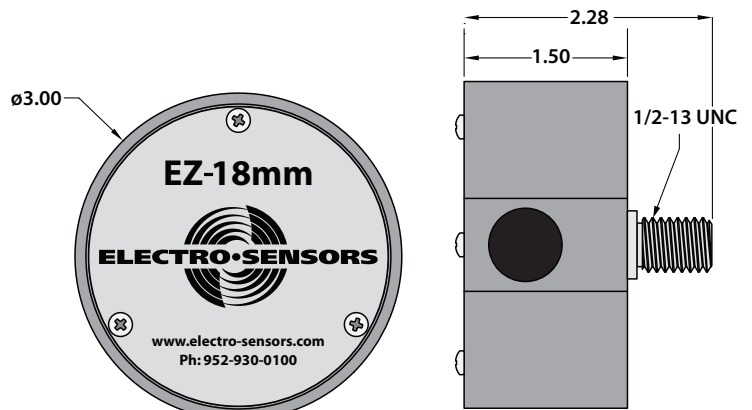

Specifications

Product	
Body Material	CPVC
Weight	8 oz.
Max Speed	300 rpm
Operating Temperature	-40 °C → 77 °C -40 °F → 170 °F
Pulses Per Revolution (PPR)	8

Mounting Magnet Option

Option (See page 3)	Part Number
*MM-1.25 Mounting Magnet	810-000060

* Can only be used with EZ Mount Brackets models EZ-3/4in and EZ-18mm

Additional Information

Please call Electro-Sensors for more information.

Ordering

Model	Part Number
EZ-3/4in, 16 Magnets (906, 932)	810-000040
EZ-18mm, 16 Magnets (Series 18, SpeedTalker-DN(BH))	810-000041
EZ-18mm, 8 Magnets (ST420 Models)	810-000042

Installation

Step 1 – Install Sensor into EZ-18mm or EZ-3/4in

1. Remove cover (3 screws).
2. Install sensor to flush with inside of housing (Gap is 1/16").
3. Tighten nut against housing (Torque to 5 ft-lbs).

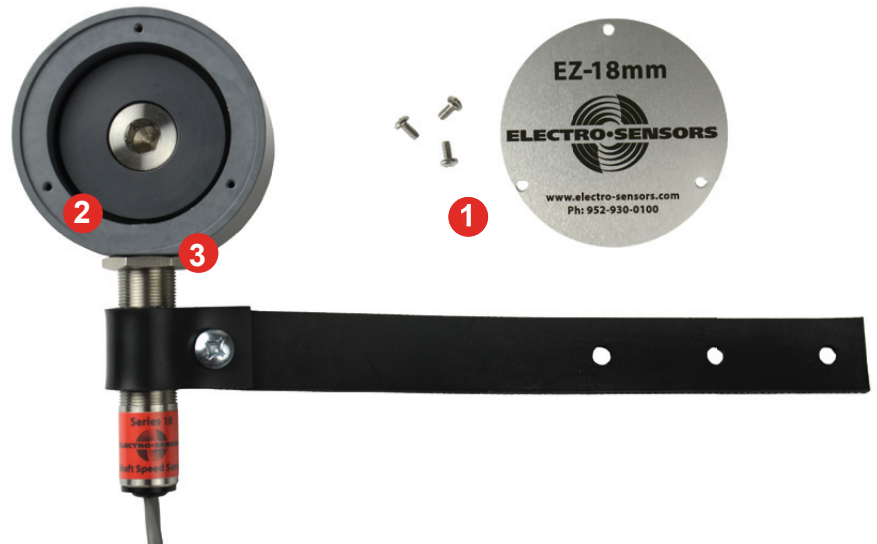

Step 2 – Install EZ-18mm or EZ-3/4in into tapped shaft

1. Put 1/2" lock washer onto shaft of EZ-3/4in or EZ-18mm.
2. Apply LocTite® 242 or equivalent to threads of shaft.
3. Tighten EZ-18mm or EZ-3/4in into shaft using 3/8" hex wrench (torque to 5 ft-lbs and allow to cure for 2 hours before use).
4. Put on cover (3 screws).
5. Attach holding strap to a secure location.

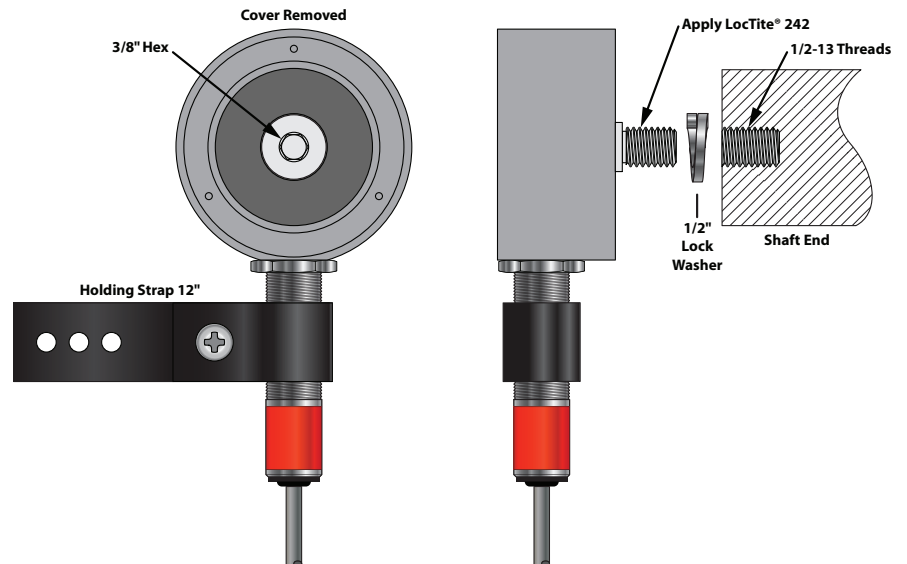

Proper lock-out and tag-out procedures must be followed during the installation procedure. The shaft must be stopped during the entire installation process.

MM-1.25 Mounting Magnet Installation Instructions

For use with the EZ-3/4in or EZ-18mm

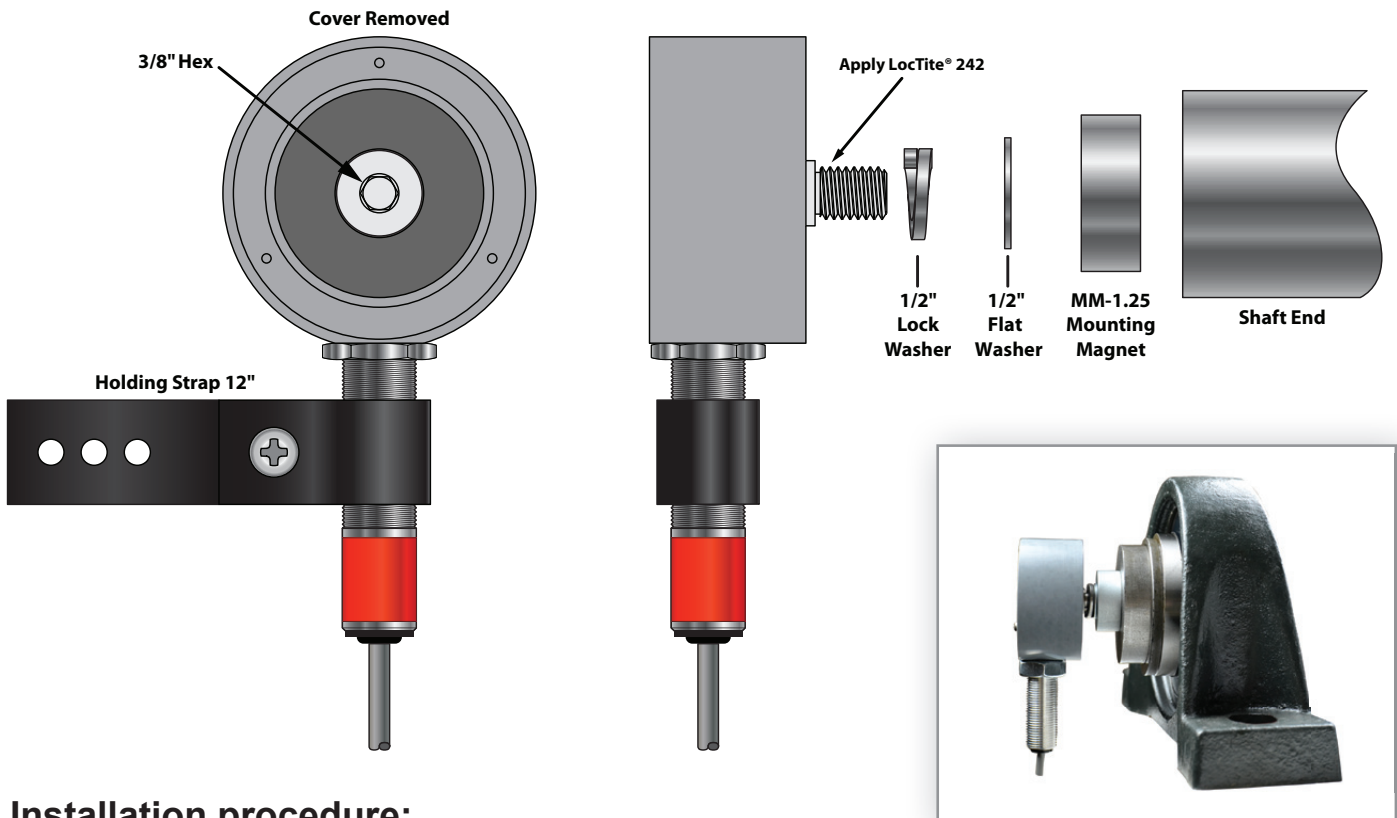

Installation procedure:

1. Remove cover of EZ-3/4in or EZ-18mm (3 screws).
2. Put 1/2" lock washer and 1/2" flat washer onto shaft of EZ-3/4in or EZ-18mm as shown above.
3. Apply LocTite[®] 242 or equivalent to threads of shaft and inside MM-1.25 mounting magnet.
4. Tighten MM-1.25 mounting magnet onto shaft of EZ-3/4in or EZ-18mm using 3/8" hex wrench and adjustable jaws pliers or pipe wrench. Torque to 5 ft-lbs. Allow to cure for 2 hours before use.
5. Put on cover (3 screws).
6. Lightly grease end of shaft with silicone grease to assist in centering mounting magnet.
7. Remove protective metal disc and spacer from face of magnet.
8. Carefully install unit onto center of the monitored shaft end. Magnet is very strong, avoid pinching fingers!
9. Attach holding strap to a secure location.

Proper lock-out and tag-out procedures must be followed during the installation procedure. The shaft must be stopped during the entire installation process. The mounting magnet is very powerful. Keep all sensitive devices such as credit cards away from the magnet since they can be damaged. Do not allow hands, fingers, or tools to come between the magnet and any ferrous material, serious injury could result.